



TY BY 191039087.004-2011



Designation
Wall bracket for console lighting

DESIGN:
Bracket is made of steel.
For lamps with fixing hole of more than 48 mm

PROTECTIVE COATING
Model K(xu) – anti-corrosion oldizinc™ and decorative coating.
*see application process and description on page 2
Model K(o) – hot zinc coating. Hot zinc coated products can be painted upon customer request.
Color on request (according to the international RAL palette).

EQUIPMENT:
Fixing elements

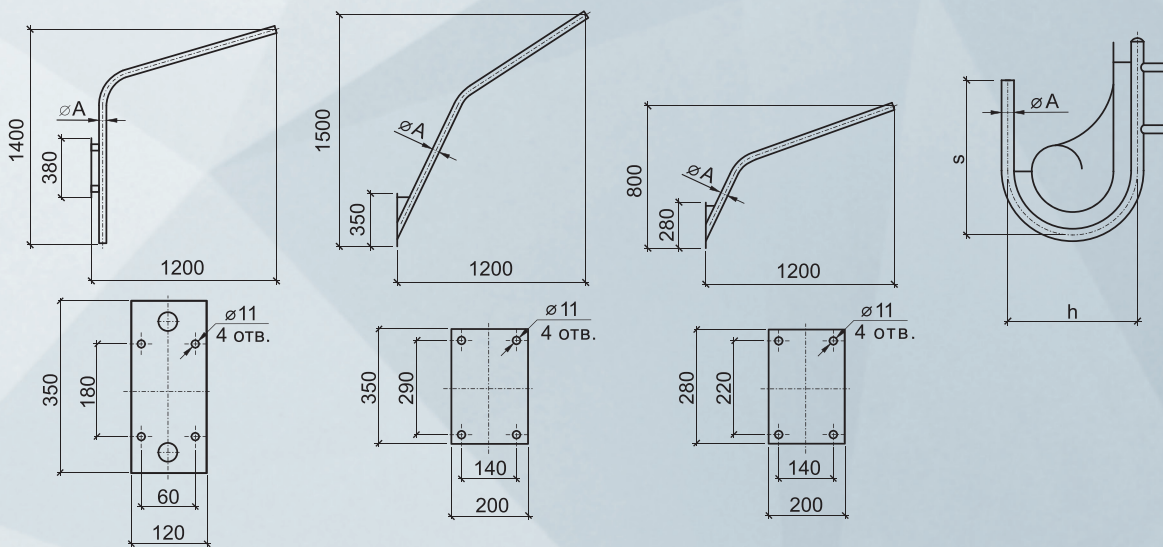

Bracket Type	h, mm	s, mm	$\varnothing A$, mm	Weight kg
K1-0.5-0.6	500	600	57	12,98
K1-1.2-1.4	1200	1400	48	10,03
K1-1.2-1.5	1200	1500	48	9,97
K1-1.2-0.8	1200	800	48	6,15

