



Designation

Metal lighting support for pedestrian streets, parks, gardens, squares.

TY BY 191039087.004-2011

DESIGN:

Steel support:
OM1 – buried;
OM1a – anchor;
 Support 3 - 5 m high

PROTECTIVE COATING

Model OM1(xu) – anti-corrosion oldizinc TM and decorative coating.
 *see application process and description on page 2

Model OM1(o)ak – hot zinc coating. Hot zinc coated products can be painted upon customer request.
 Color on request (according to the international RAL palette).

EQUIPMENT:

1. Cable – on request
2. Entry panel (see pages 104-105) – on request

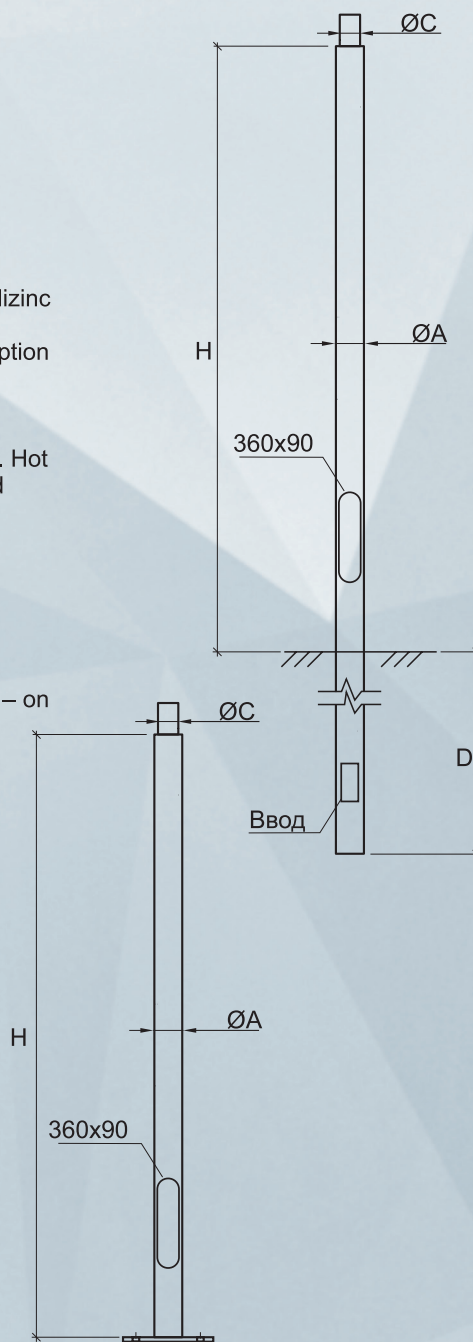

PARAMETER SHEET OM1a SAXON

Type of support	H, м	øA, мм	øC, мм	Anchor	Foundation block	Weight, kg
OM1a-1-3.0-108	3,0	108	76	Ша 16x4x1200	ФБ-2-L-1200	32,02
OM1a-1-4.0-108	4,0	108	76			39,79
OM1a-1-5.0-108	5,0	108	76			47,56

PARAMETER SHEET OM1a SAXON

Type of support	H, м	D, мм	øA, мм	øC, мм	Weight, kg
OM1-1-3.0-108	3,0	1200	108	76	35,43
OM1-1-4.0-108	4,0	1200	108	76	43,22
OM1-1-5.0-108	5,0	1200	108	76	50,99