

OM23

TY BY 191039087.004-2011

OM23a

Designation

Metal lighting support for streets, parks, squares.

DESIGN:

Steel support

OM23a - anchor

PROTECTIVE COATING

Model OM23(хц)а – oldizinc™ coating and painting with RAL finishing layer.

Model OM23(о)а – hot zinc coating. Hot zinc coated products are painted with RAL finishing layer or covered with polymer coating. Color on request (according to the international RAL palette).

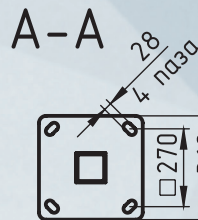
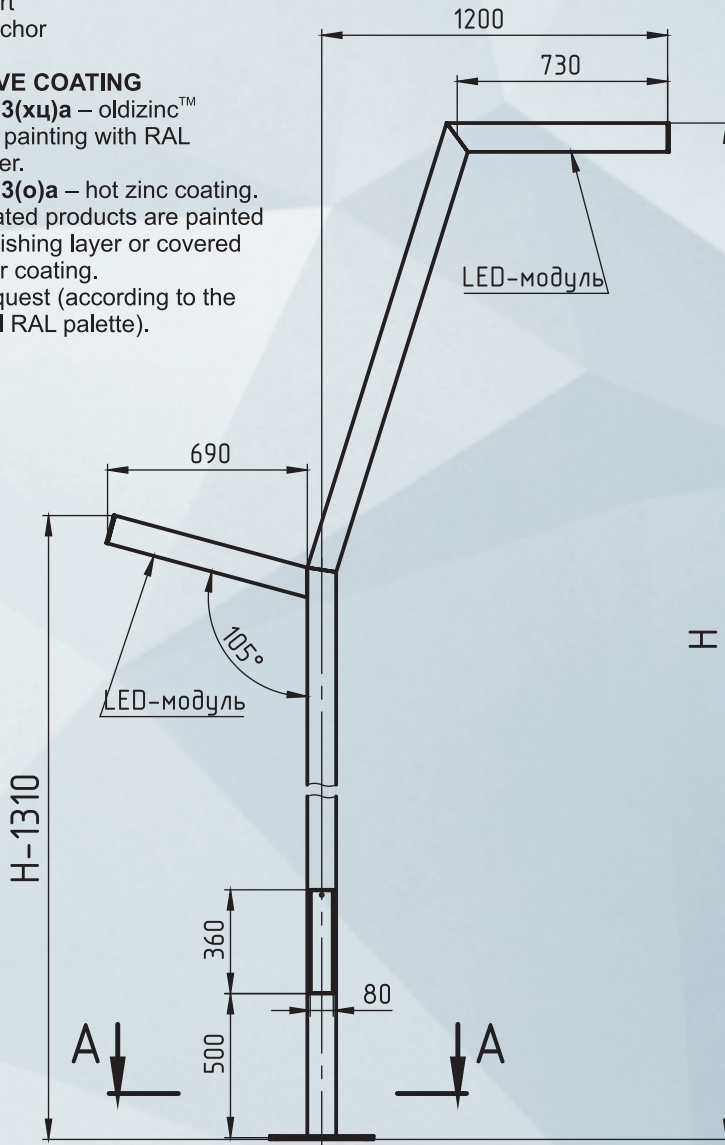

EQUIPMENT:

1. LED lamp 20-80 W (secondary optics – lenses)
2. Cable on request
3. Entry panel on request (see pages 104-105)
4. Embedded element is a separate item.

PARAMETER SHEET OM23a

Type of support	H, m	L1×L2, mm	Weight, kg	Anchor	Foundation Block
OM23a-2-4,0-100x100	4,0		81		
OM23a-2-5,0-100x100	5,0	360×80	93,5	Ша 20×4×1500(1)	ФБ-2-L-1500(1)
OM23a-2-6,0-100x100	6,0		105,3		